

Model: AMS-500 AMS-1000 / AMS-1500

AMS series with fixed forks

| Model | | AMS-500 | AMS-1000 | AMS-1500 |
|---|------------|-------------------|--------------------------|-------------------|
| Load capacity/rated load | Q(kg) | 500 | 1000 | 1500 |
| Load centre distance | c(mm) | 600 | 600 | 400 |
| Fork height, lowered | h_1 (mm) | 90 | 90 | 90 |
| Height, mast lowered | h_2 (mm) | 1490/2080 | 1490/1720/2080/1838/2080 | 2080 |
| Max. lift height | h_3 (mm) | 1000/1600 | 1000/1200/1600/2500/3000 | 1600 |
| Height, mast extended | h_4 (mm) | 1490/2080 | 1490/1720/2080/2925/3420 | 2080 |
| Overall length | l(mm) | 1655/1705 | 1655/1705 | 1655/1705 |
| Overall width | b(mm) | 755 | 755/755/755/860/860 | 755 |
| Fork dimensions | s/e/l(mm) | 61/170/1100(1150) | 61/170/1100(1150) | 61/170/1100(1150) |
| Width overall forks | b_1 (mm) | 550 | 550/550/550/580/580 | 550 |
| Ground clearance, laden, below mast | m(mm) | 25 | 25 | 25 |
| Aisle width for pallets 1000x1200 crossways | A_c (mm) | 2112 | 2112 | 2112 |
| Aisle width for pallets 800x1200 lengthways | A_l (mm) | 1945 | 1945 | 1945 |
| Turning radius | W(mm) | 1380 | 1380 | 1380 |
| Lift speed,laden/unladen | mm/time | 25 | 25 | 21 |
| Lowering speed,laden/unladen | mm/s | Manual control | | |
| Service weight | kg | 185 / 205 | 183/191/240/280/303 | 236 |

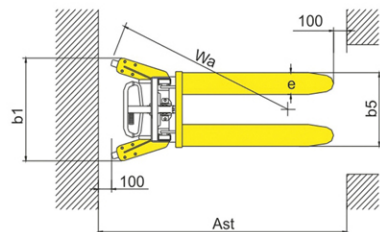
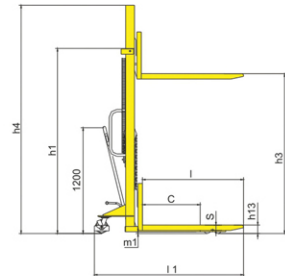

Conforms to EN ISO3691-5:2014
Based on Directive 2006/42/EC

Hand Pallet Truck



Model: APT-3000

1KG=2.205LB 1INCH=25.40MM

| Model | APT 3000 | | |
|---|------------|----------------|--------------|
| Capacity | Q(kg) | 2000/2500/3000 | |
| Lowered fork height | h_0 (mm) | 85 | 75 |
| Steering wheel | mm | ϕ 200 | ϕ 180 |
| Fork wheel single | mm | ϕ 80x93 | ϕ 74x93 |
| Fork wheel tandem | mm | ϕ 80x70 | ϕ 74x70 |
| Max. lift height | h_1 (mm) | 200 | 190 |
| Total height | h_2 (mm) | 1232 | 1222 |
| Overall length | L_1 (mm) | 1533/1603 | 1533/1603 |
| Fork length | l (mm) | 1150/1220 | 1150/1220 |
| Width overall forks | b_0 (mm) | 520/550/685 | 520/550/685 |
| Ground clearance, centre of wheelbase | m_1 (mm) | 32 | 22 |
| Aisle width for pallets 1000x1200 crossways | A_c (mm) | 1733/1803 | 1733/1803 |
| Aisle width for pallets 800x1200 lengthways | A_l (mm) | 1783/1803 | 1783/1803 |
| Turning radius | W_0 (mm) | 1265/1335 | 1265/1335 |
| Service weight | kg | 55-70 | 55-70 |



Conforms to EN ISO3691-5:2014
Based on Directive 2006/42/EC

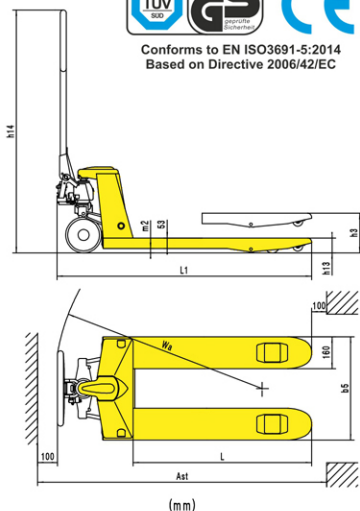

Excellent type pallet truck

- Standard single speed pump and light service weight, but big load capacity 3000kgs.
- Design on the base of 3 years service time, which can be extended up to 5 years.
- Compact appearance, complete rocker arms, ensure the whole truck averaged pressed.
- Full sealed pump, easy to maintain.
- Simplified spare parts, higher performance with low repair cost.
- Option: 1) Double Speed Pump.
2) Nylon wheel, polyurethane wheel, rubber wheel, single fork roller or tandem fork rollers.
3) Fork length: 800mm, 900mm, 1000mm, 1100mm.

Model: AES-10 / AES-15



| Model | | Fix type forks | |
|---|------------|-----------------------|-------------|
| | | AES-10 | AES-15 |
| Load capacity | Q (kg) | 1000 | 1500 |
| Load centre distance | c (mm) | 500 | 500 |
| Load distance, centre of drive axle to fork | x (mm) | 802 | 802 |
| Tyre size, front | mm | φ 180x50 | φ 180x50 |
| Tyre size, rear | mm | φ 80x70 | φ 80x70 |
| Wheels, number front rear(x=driven wheels) | | 2/2 | 2/2 |
| Height, mast lowered | h_1 (mm) | 2090/1840/2090 | |
| Max. lift height | h_2 (mm) | 1600/2500/3000 | |
| Height, mast extended | h_3 (mm) | 2090/3060/3560 | |
| Overall length | l_1 (mm) | 1678 | 1740 |
| Length to face of forks | l_2 (mm) | 608 | 670 |
| Overall width | b_1 (mm) | 800 | 800 |
| Fork dimensions | s/e/l (mm) | 60/170/1070 | 60/170/1070 |
| Width overall forks | b_2 (mm) | 580/695 | 580/695 |
| Aisle width for pallets 800x1200 lengthways | A_p (mm) | 2267 | 2347 |
| Turning radius | W_r (mm) | 1425 | 1505 |
| Lift speed, laden/unladen | m/s | 0.08/0.1 | 0.08/0.1 |
| Lowering speed, laden/unladen | m/s | 0.15/0.12 | 0.15/0.12 |
| Service brake | | mechanical | mechanical |
| Battery voltage, nominal capacity K_n | V/Ah | 12/120 | 12/120 |
| Battery weight | kg | 45 | 45 |
| Battery dimensions l/w/h | mm | 360x170x250 | 360x170x250 |
| Service weight (with battery) | kg | | |

Option of battery for CDD15B-III: 24V/120Ah

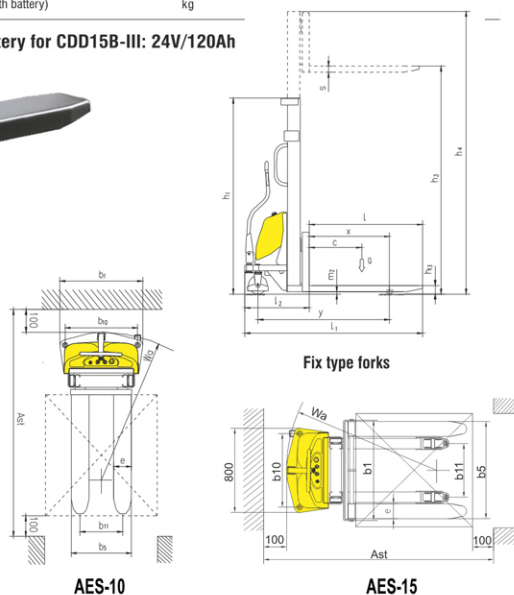

Conforms to EN ISO3691-5:2014
Based on Directive 2006/42/EC